

# **DÉVELOPPEMENT HYBRIDE**

POINTE SAINT-CHARLES

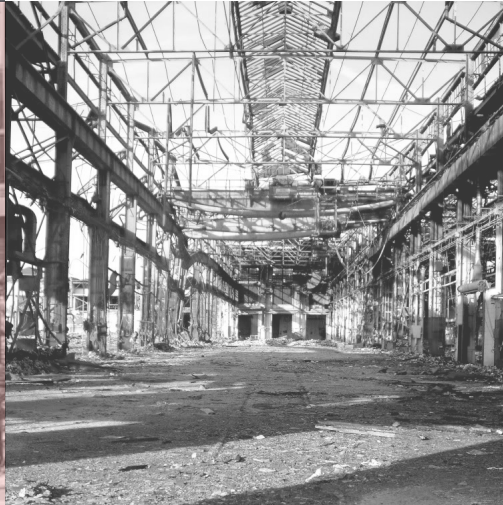



# POINTE SAINT CHARLES

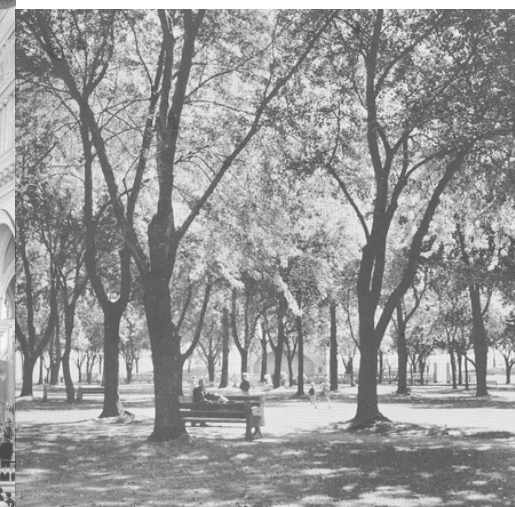
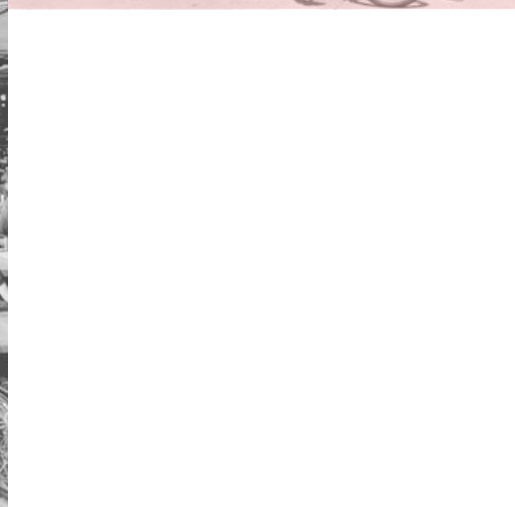



# CONTEXTE ÉLARGIE

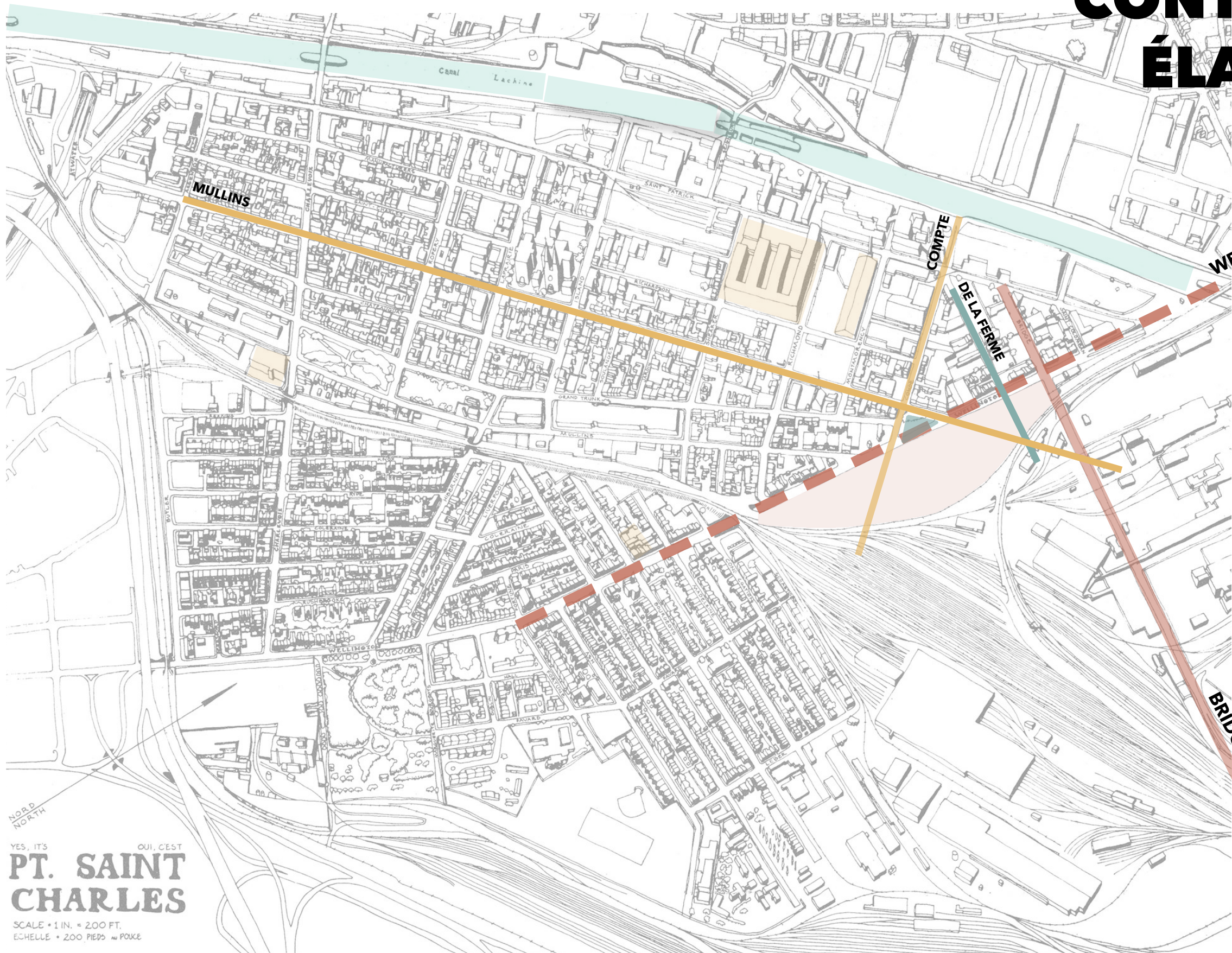

AXES PRINCIPAUX  
WELLINGTON

NORD  
NORTH

YES, IT'S  
**PT. SAINT  
CHARLES**  
OUI, C'EST

SCALE • 1 IN. = 200 FT.  
ECHELLE • 200 PIEDS AU POUCE



# TYPOLOGIES BÂTIMENTS

PAR RAPPORT AUX TYPOLOGIES DE BÂTIMENTS  
QU'ON RETROUVE DANS LE CONTEXTE URBAIN.

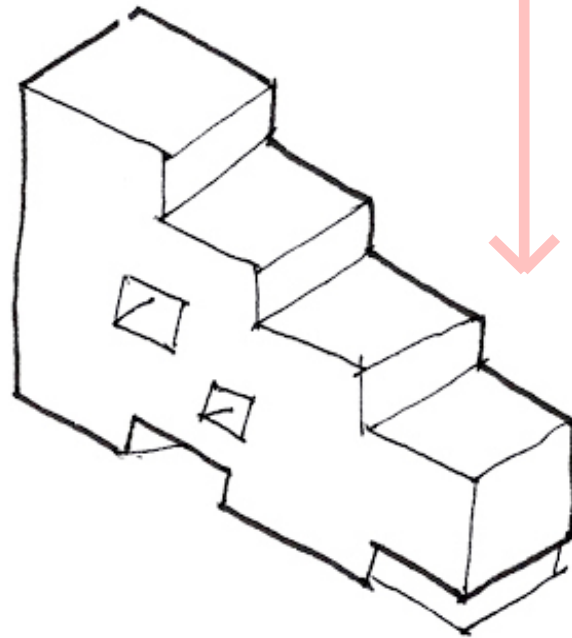
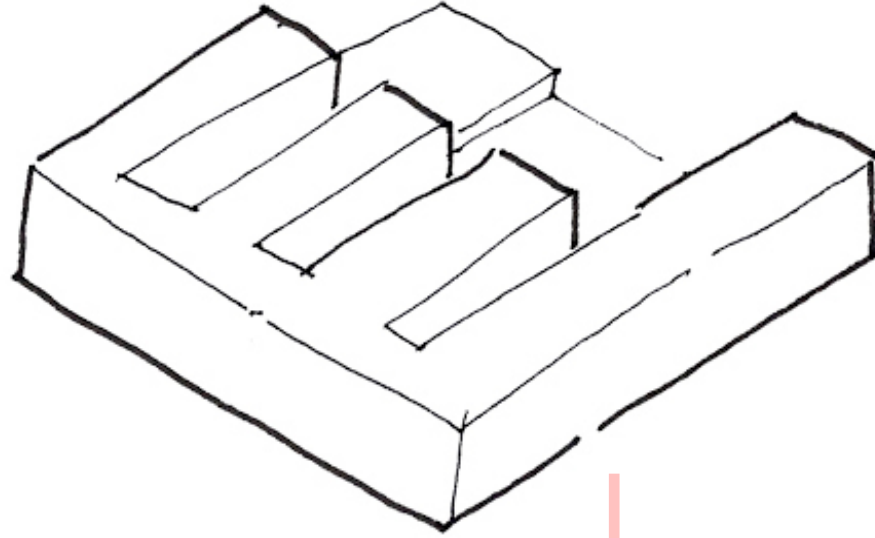

**TOURS MIXTES**

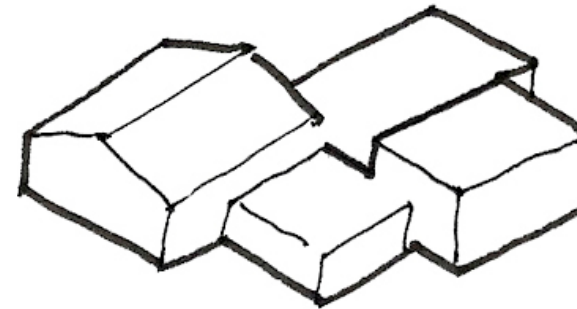
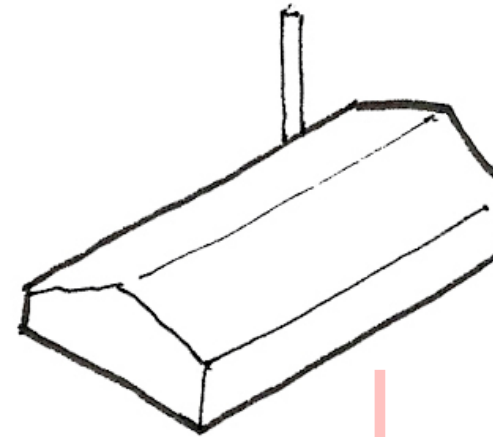

**PETITES USINES**

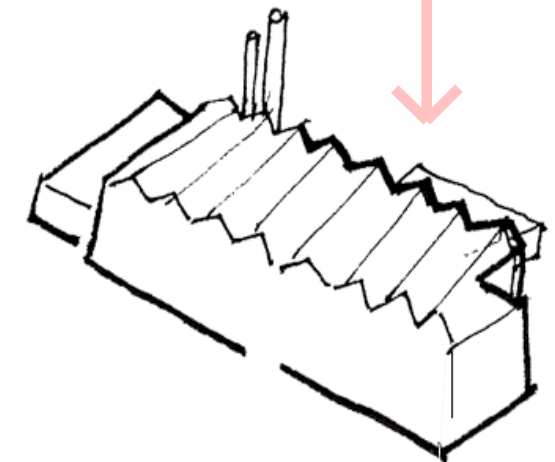
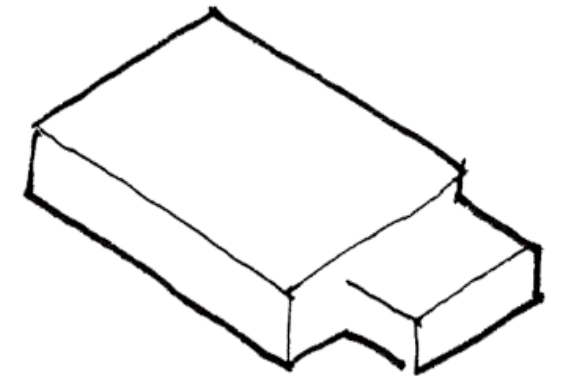

**GRANDES USINES**

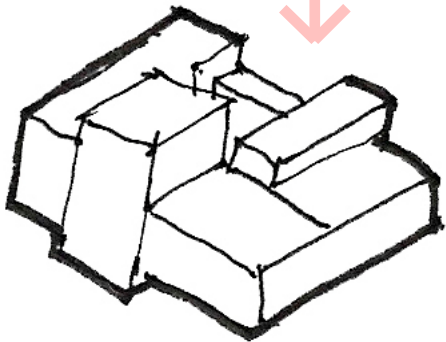
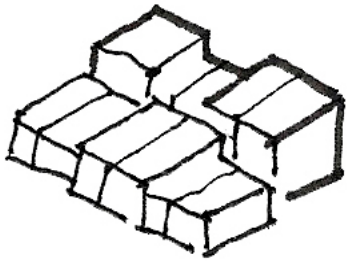

**COOP CENTRALE**



# LIENS AVEC LE QUARTIER

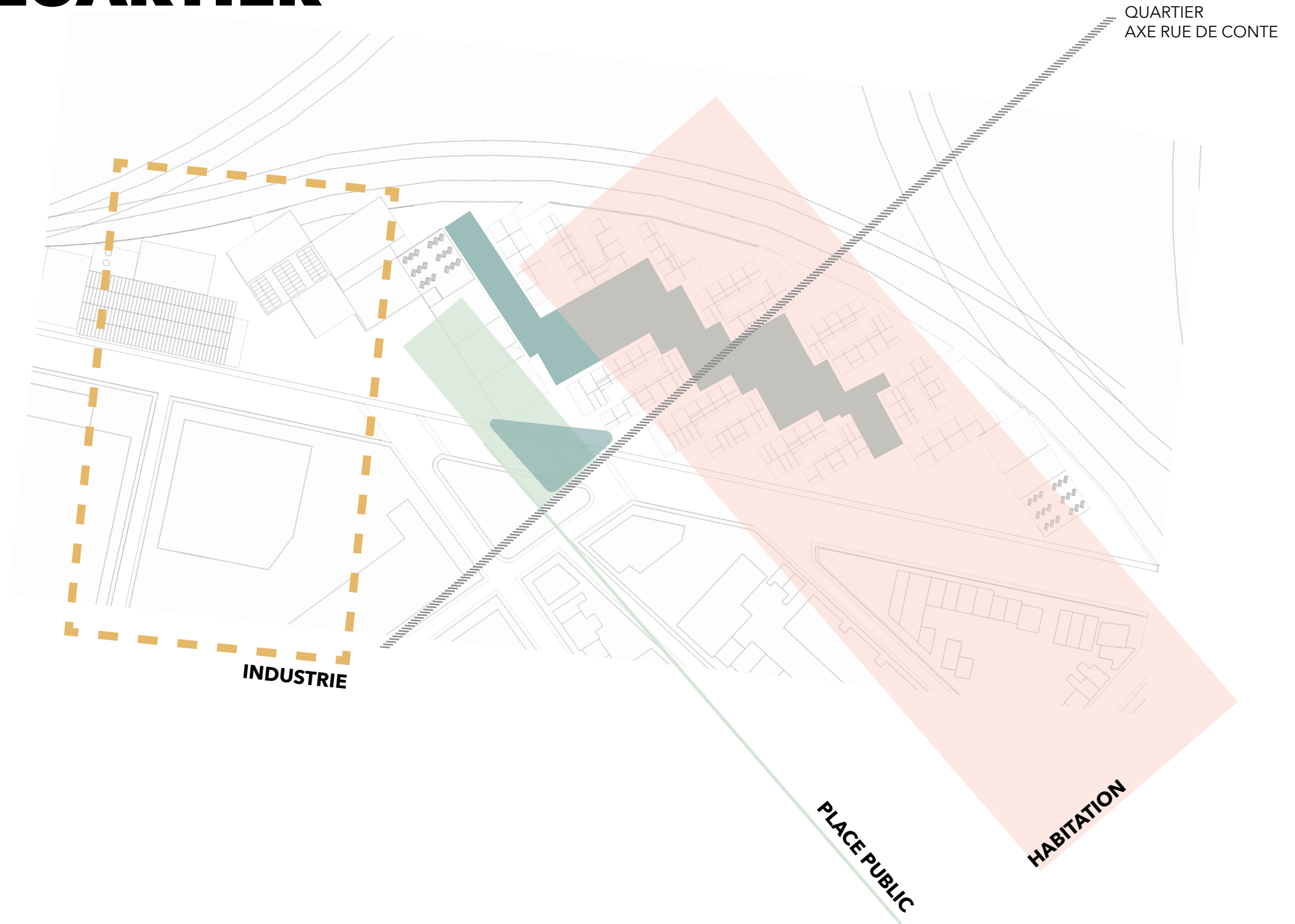



# SYNERGIE ET COMMUNAUTÉ

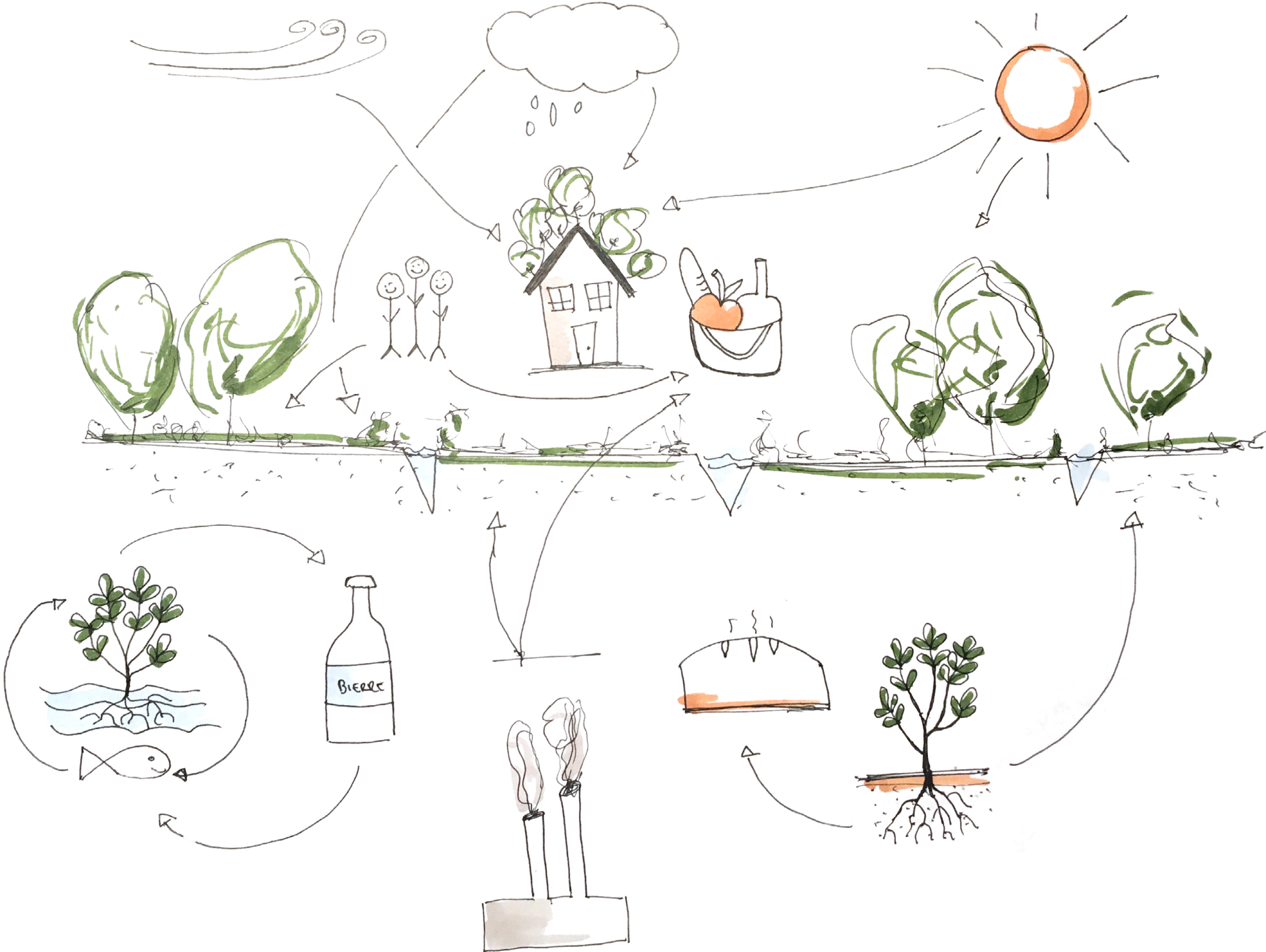



# CONCEPT DES PERFORATIONS

RAPPORT ENTRE LES ÉCHELLES, PRINCIPE  
CONCEPTUELLE DIMENSIONNANT LES ÉLÉMENTS.

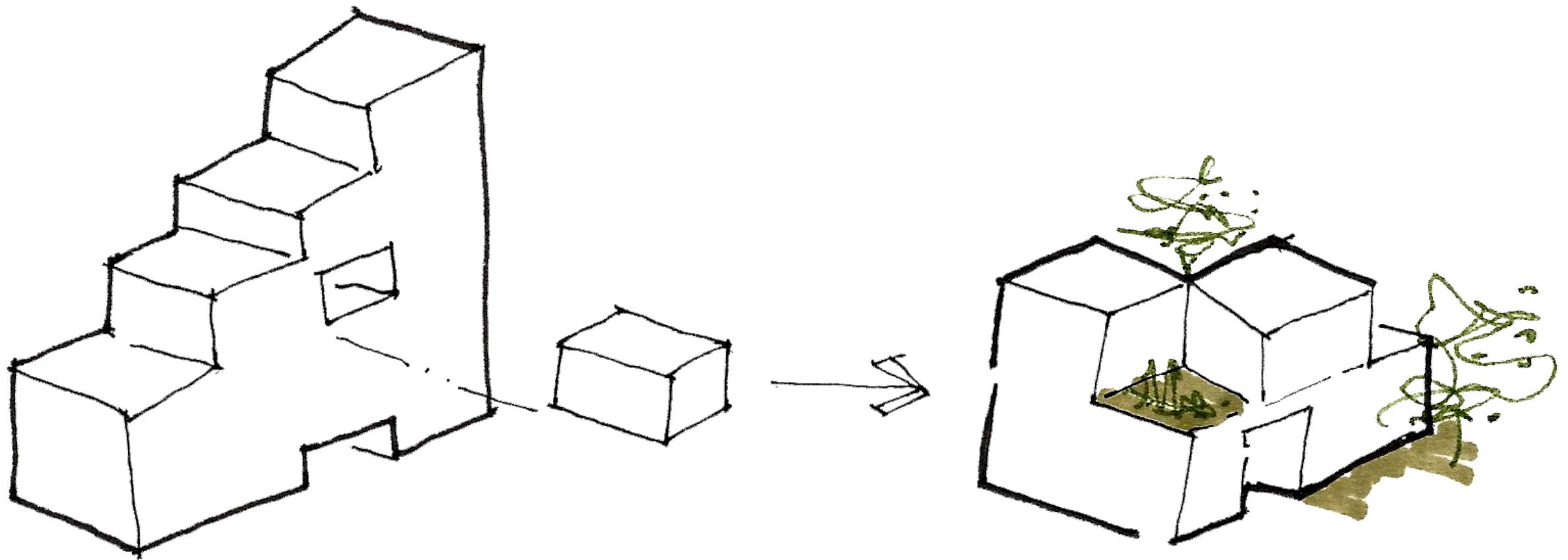

01  
PASSERELLE-  
TRANSITION.

02

03  
BASSIN  
RETENTION -  
ESPACE DIFFUSION  
-TEUX.

04  
PROMENADE  
TANNIN - VERGER

05  
TERRAIN  
VASTE.

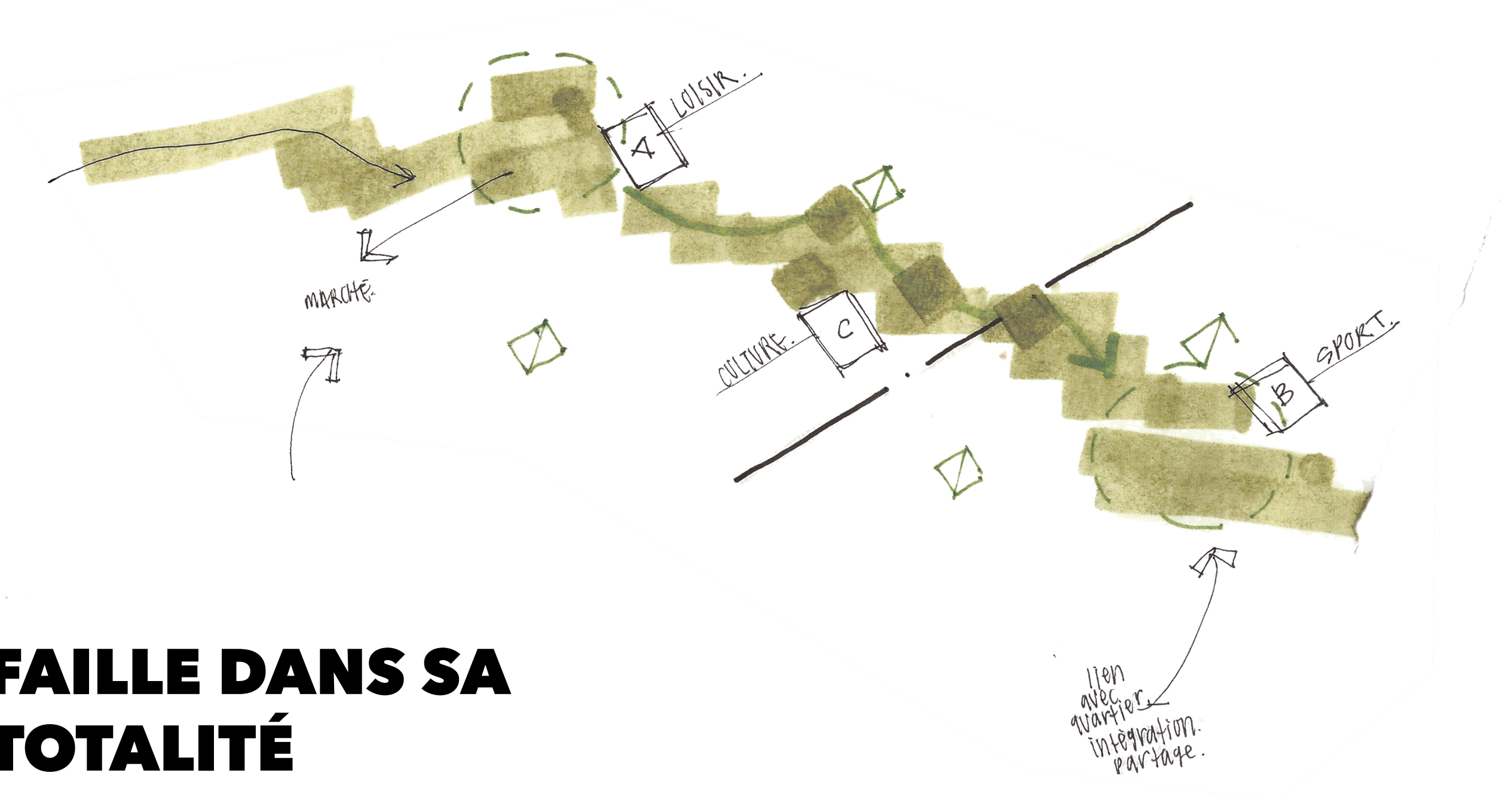

**FAILLE DANS SA  
TOTALITÉ**





LA PROMENADE  
découverte + relaxer.



LE POTAGER  
production + apprentissage.



LE BASSIN DE RÉTENTION  
récupération vs espace diffusion /jeux



LE VERGER  
production + partage vs détente à l'ombre.

# COUPES DE FAILLE VÉGÉTALE

# DÉTAILS FAILLE ENTRÉE COOP

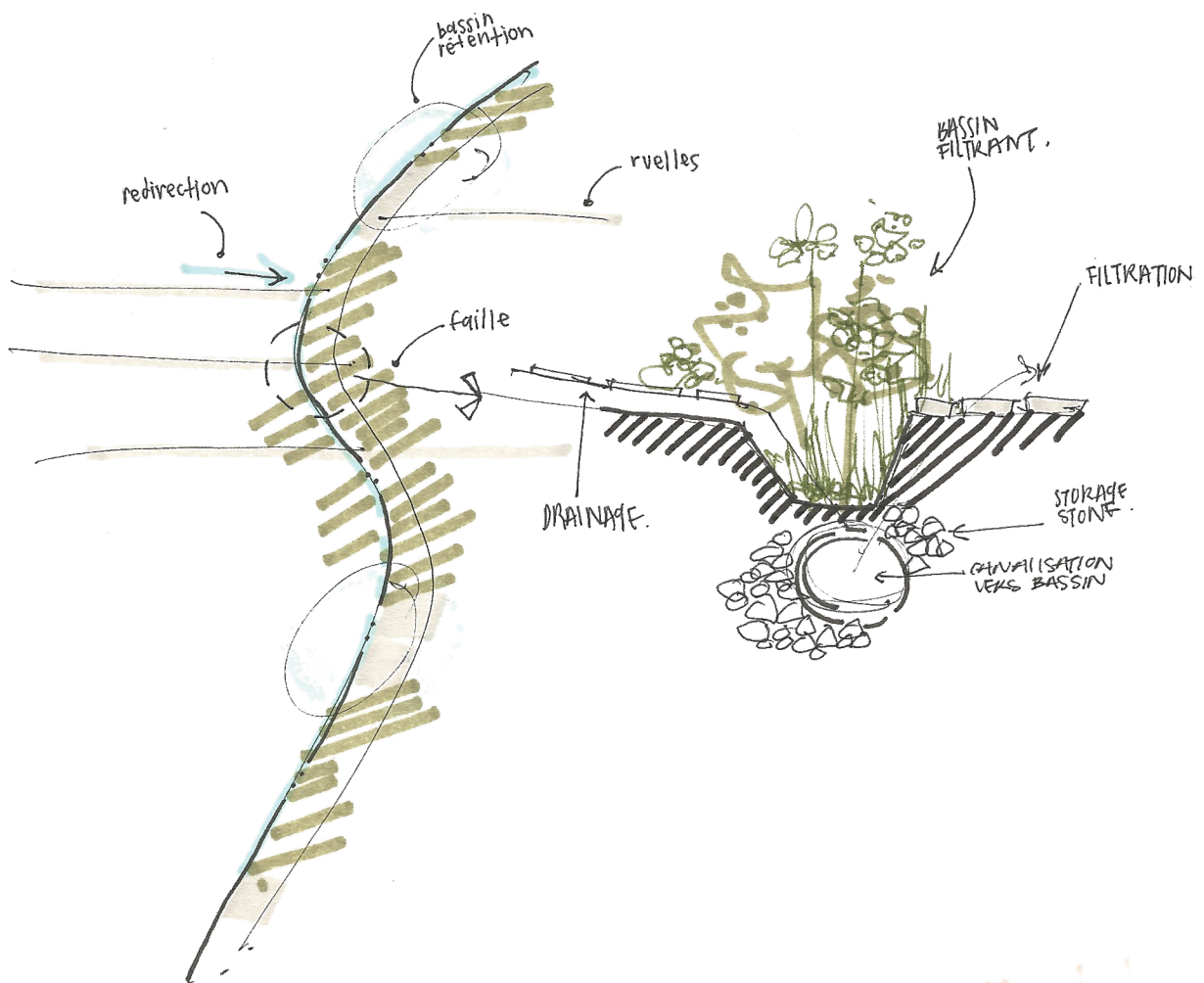

SAUVAGE  
MINÉRALISÉ  
VRBAIN.

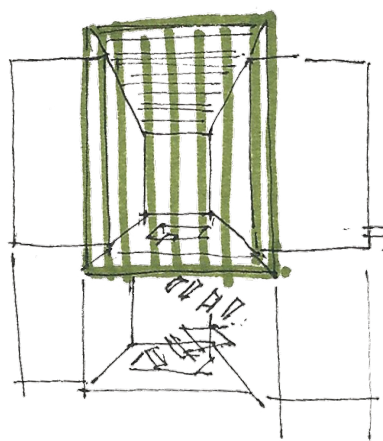

importance  
du regard au ciel  
à l'horizon et  
proximité

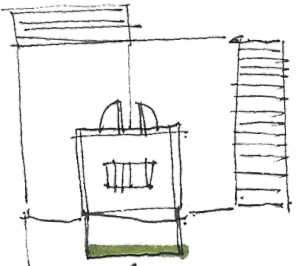
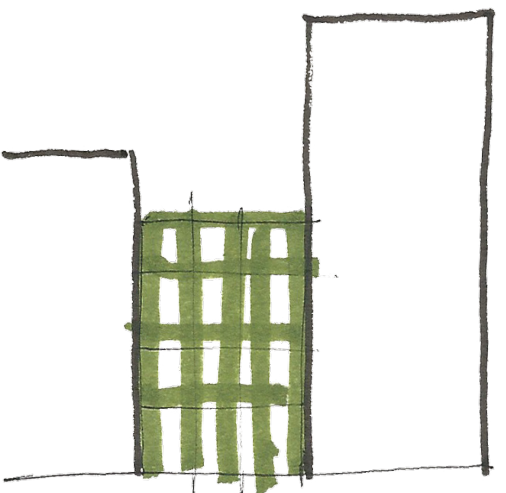

escalier type  
montréalaise +  
cultivation.

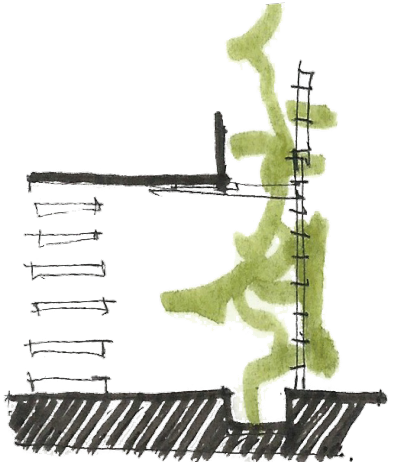



# DENSITÉ DE L'HABITATION



# COUPE LONGITUDINALE

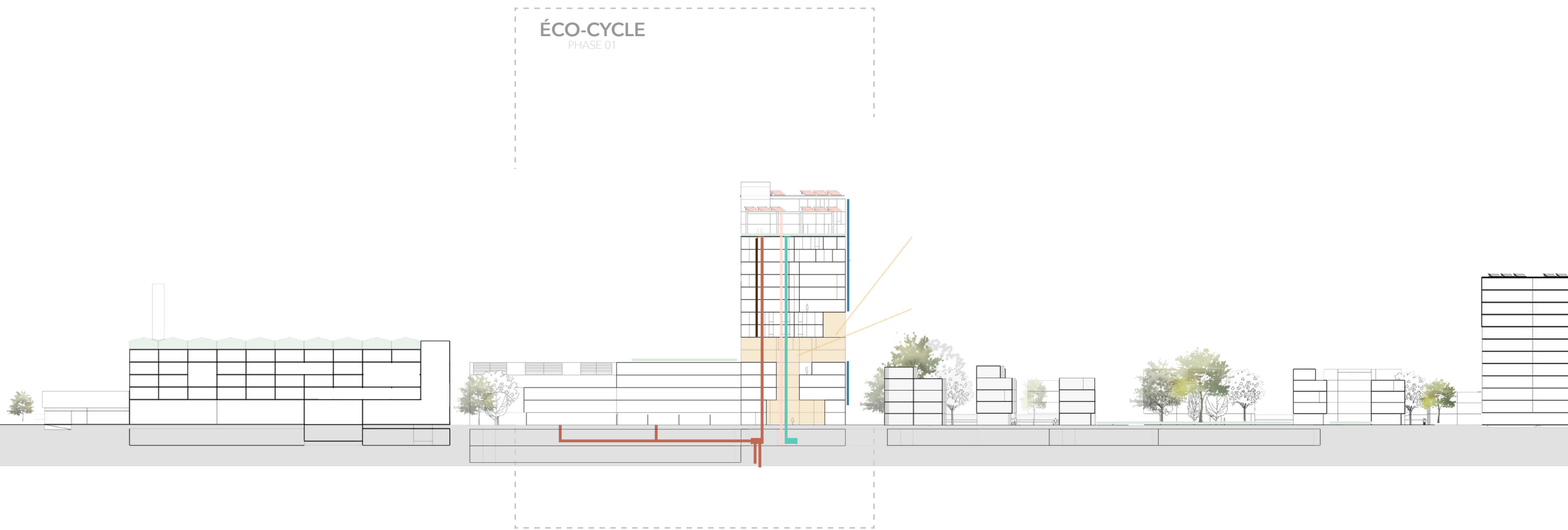



# **PLANS ET IMPLANTATION**

DANS LA VILLE, LE QUARTIER ET LE SITE





# **LE SITE ET SON CONTEXTE ÉLARGI**





# PLAN DU REZ-DE-CHAUSSÉE

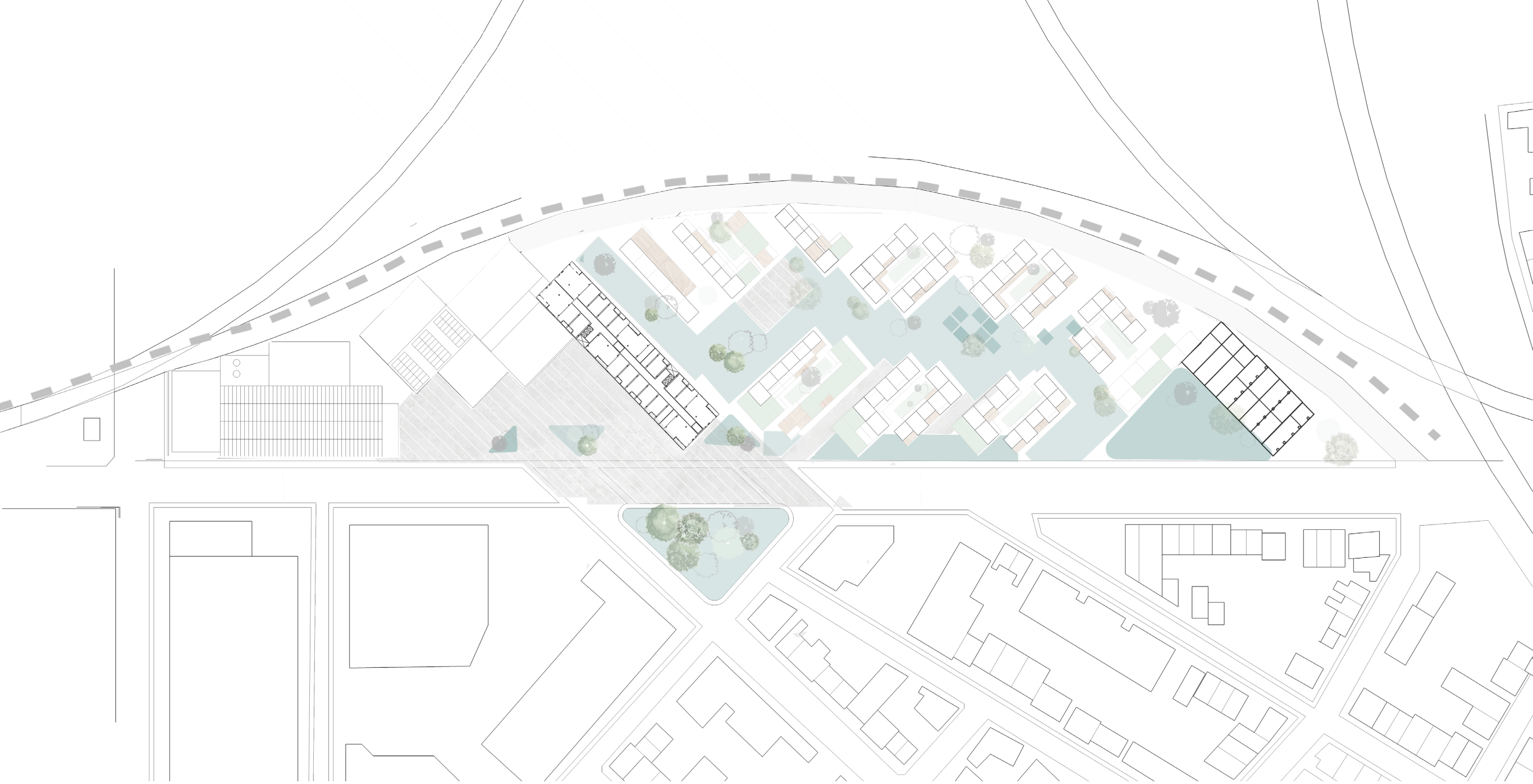

# PLAN D'UN ÉTAGE TYPE



**DÉVELOPPEMENT**

**DES COOP**

COOPÉRATIVES D'HABITATIONS

# JUXTAPOSITION EMBOÎTEMENT

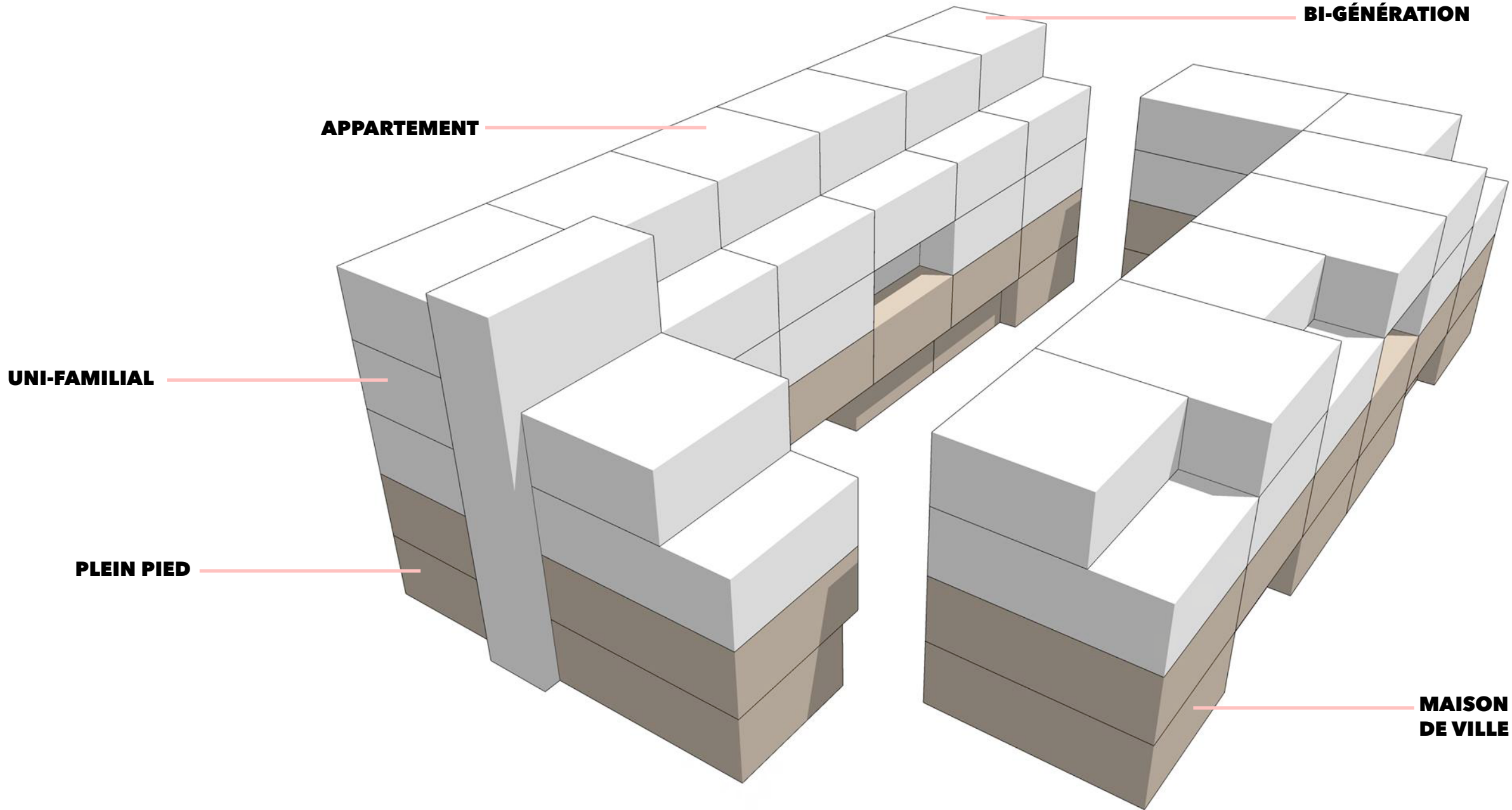



# ÉCHELLES ET DIMENSIONS

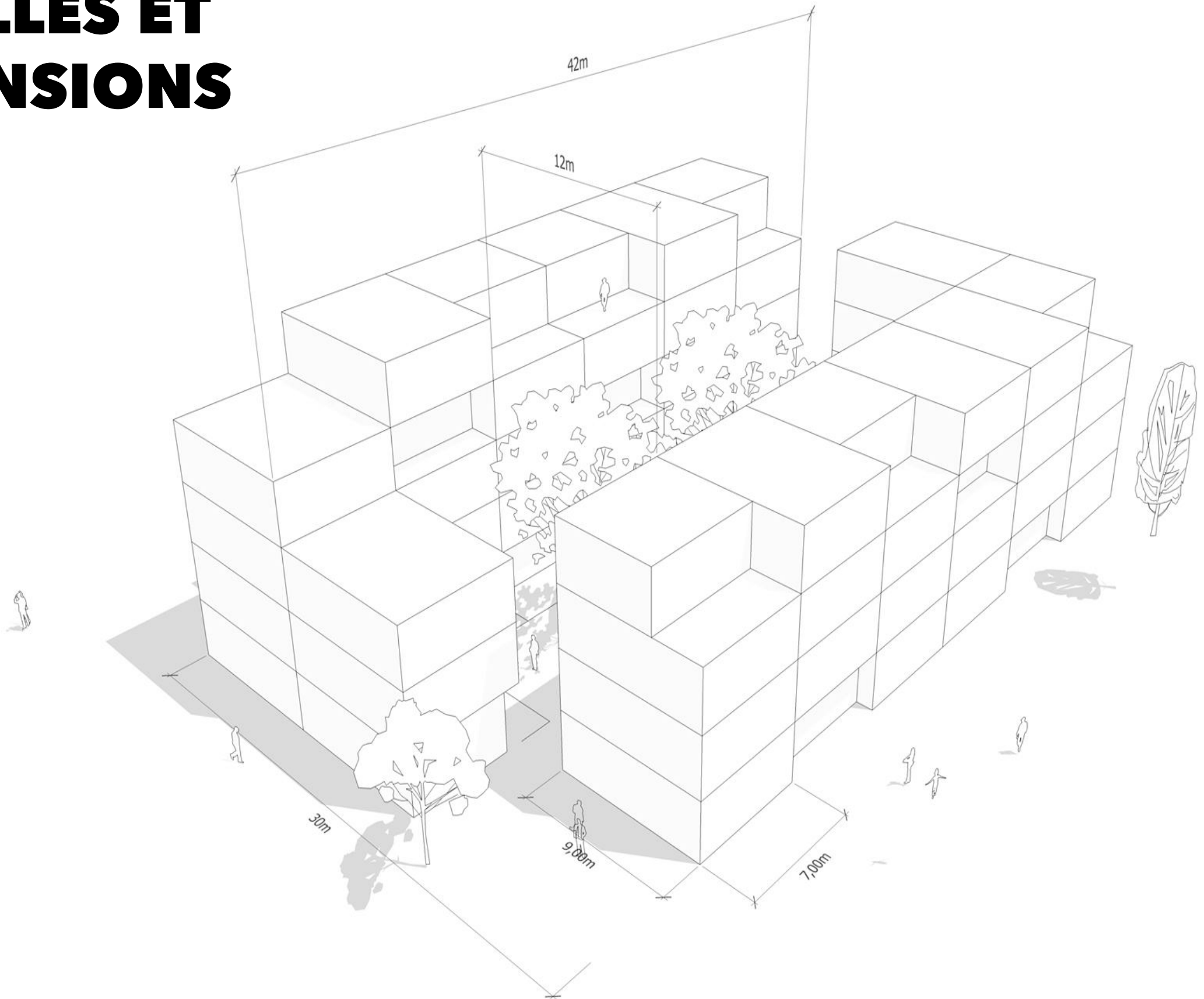

# COUPE D'UNE COOPÉRATIVE

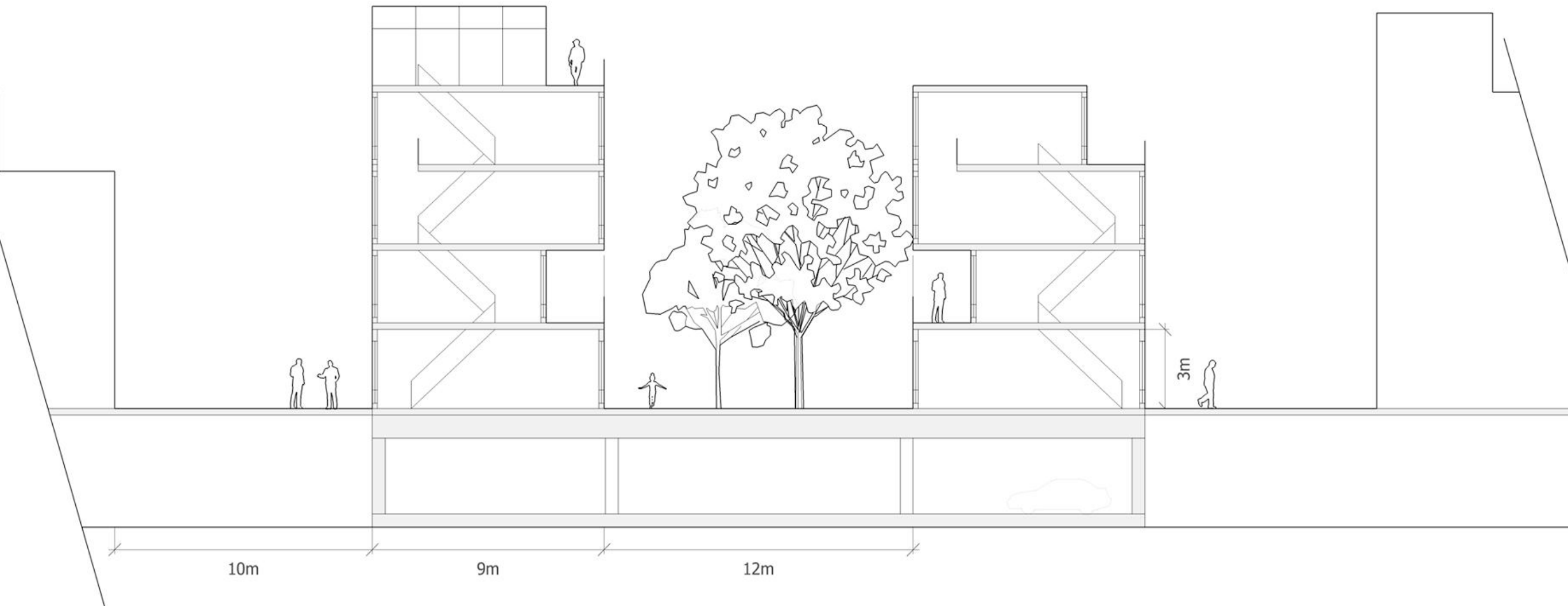

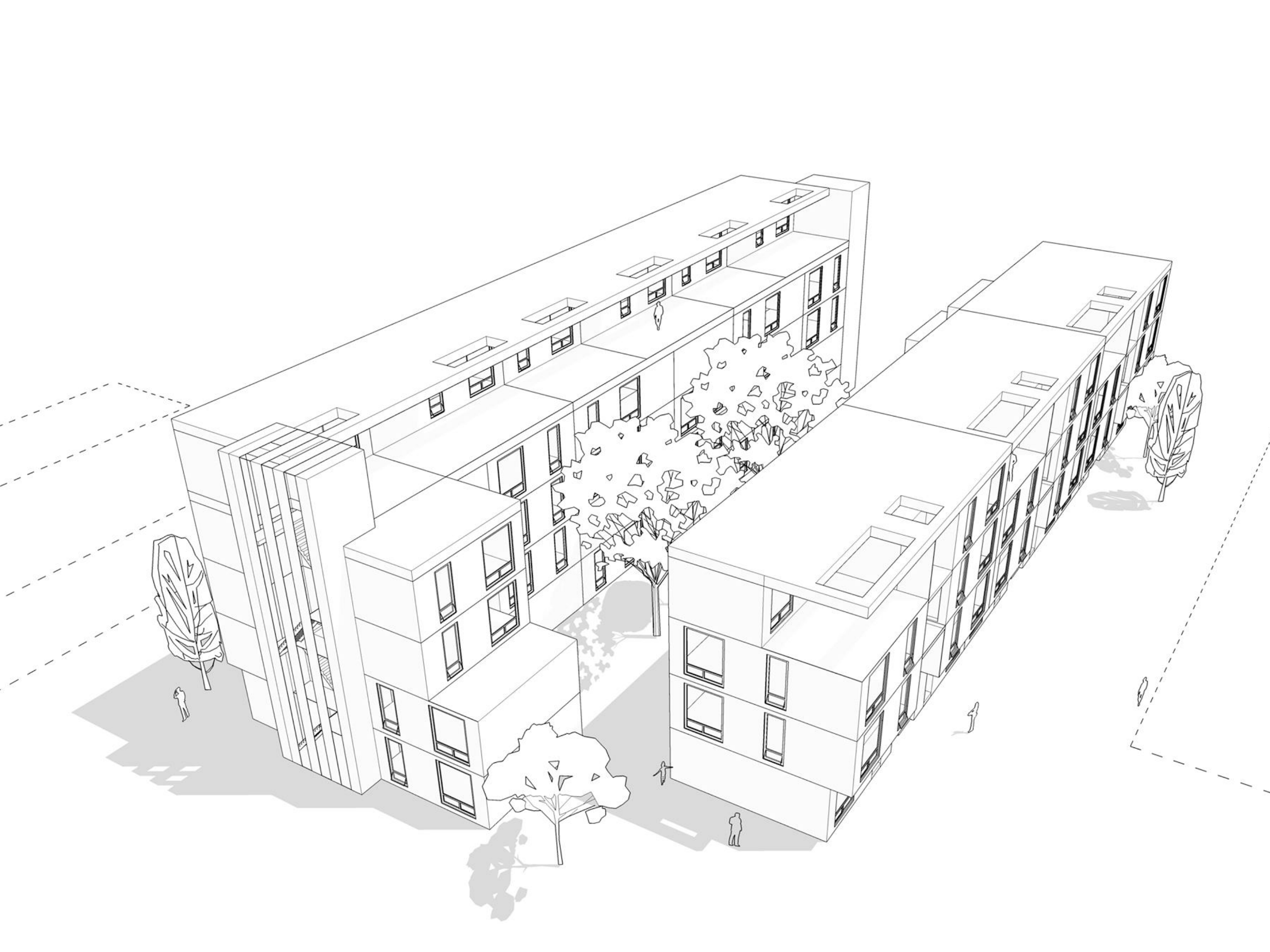



**APPARTEMENTS**

**TYPES**

TOURS D'HABITATION

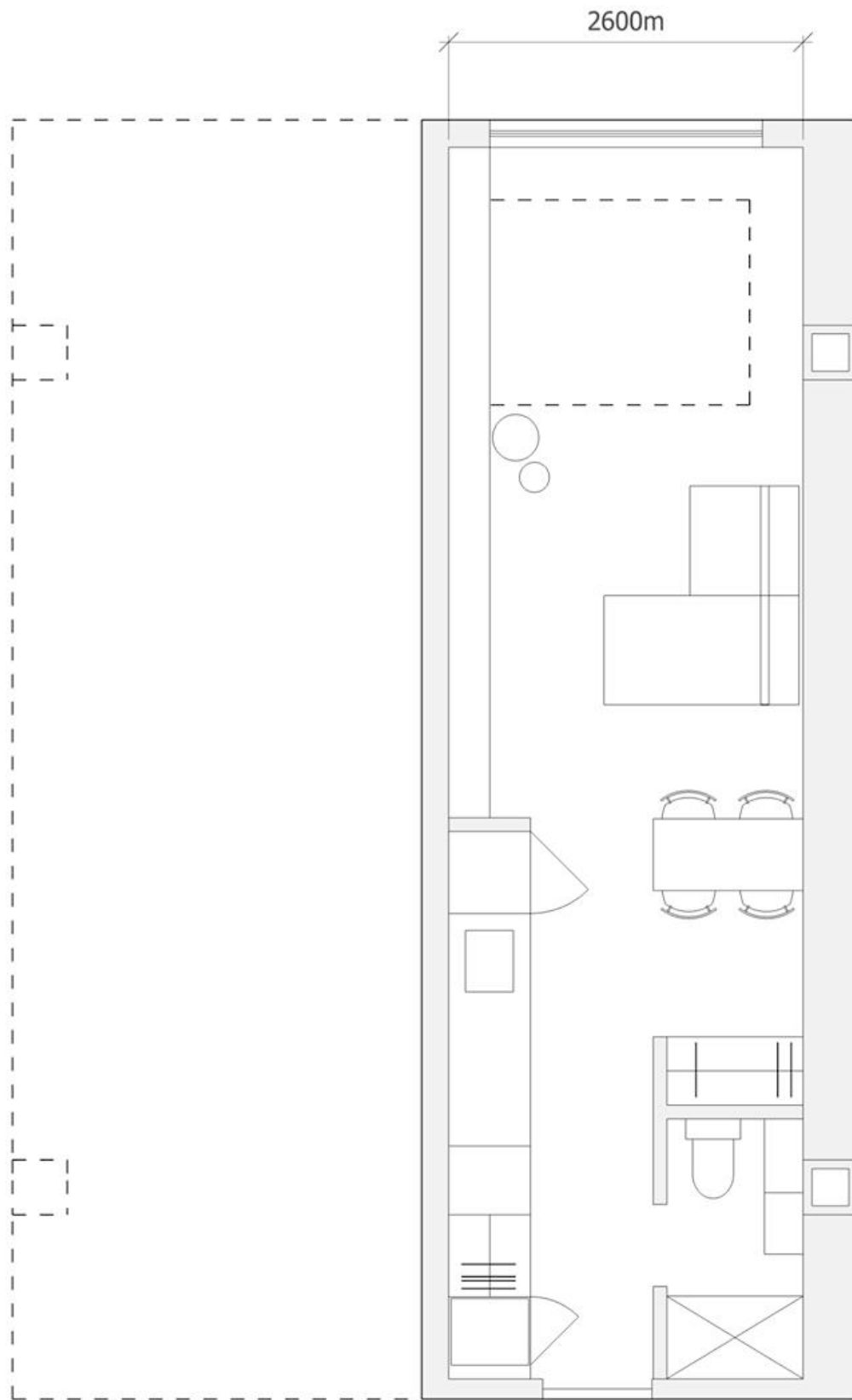

**STUDIO**

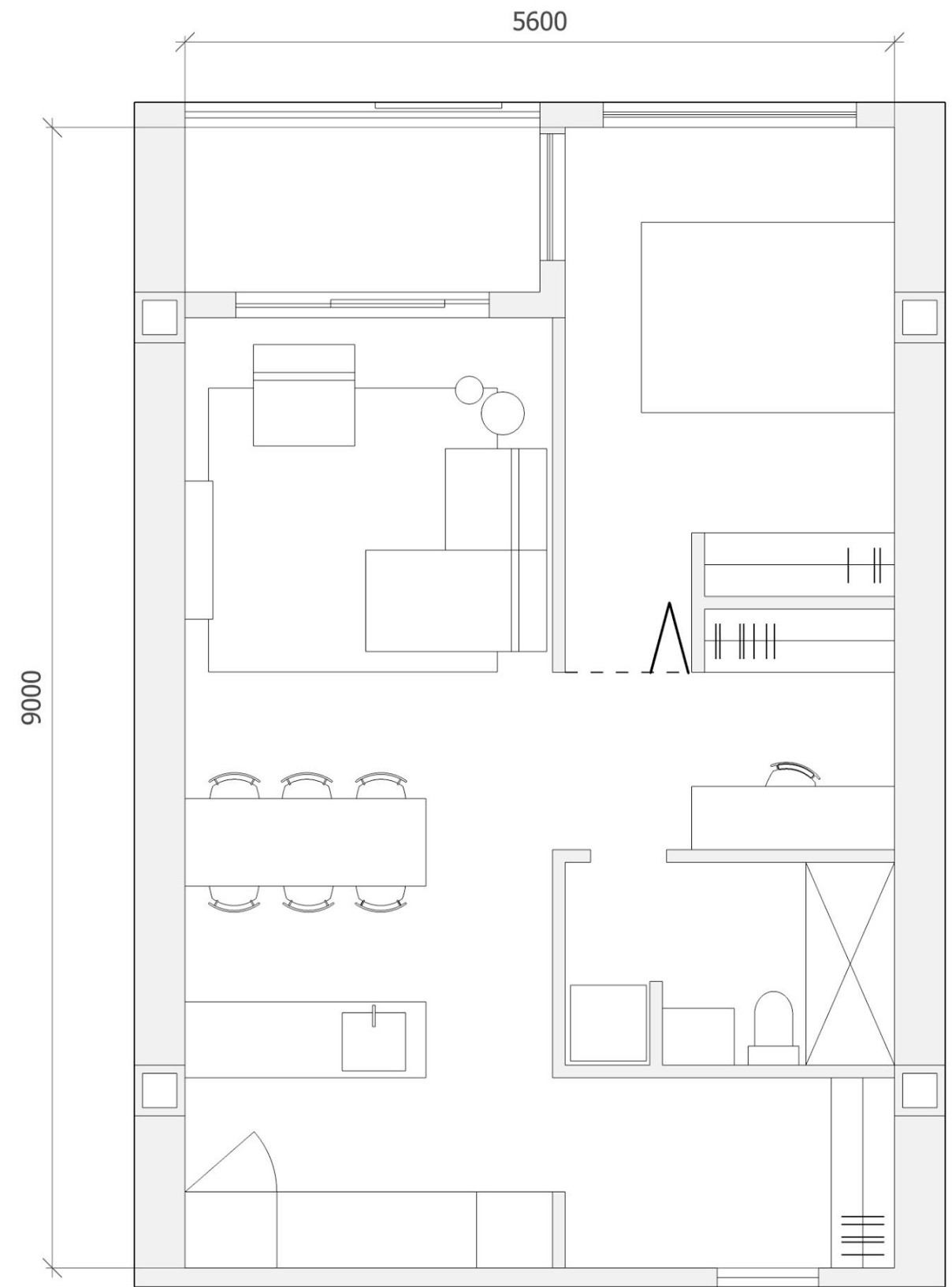

**1 CHAMBRE**



11 600m

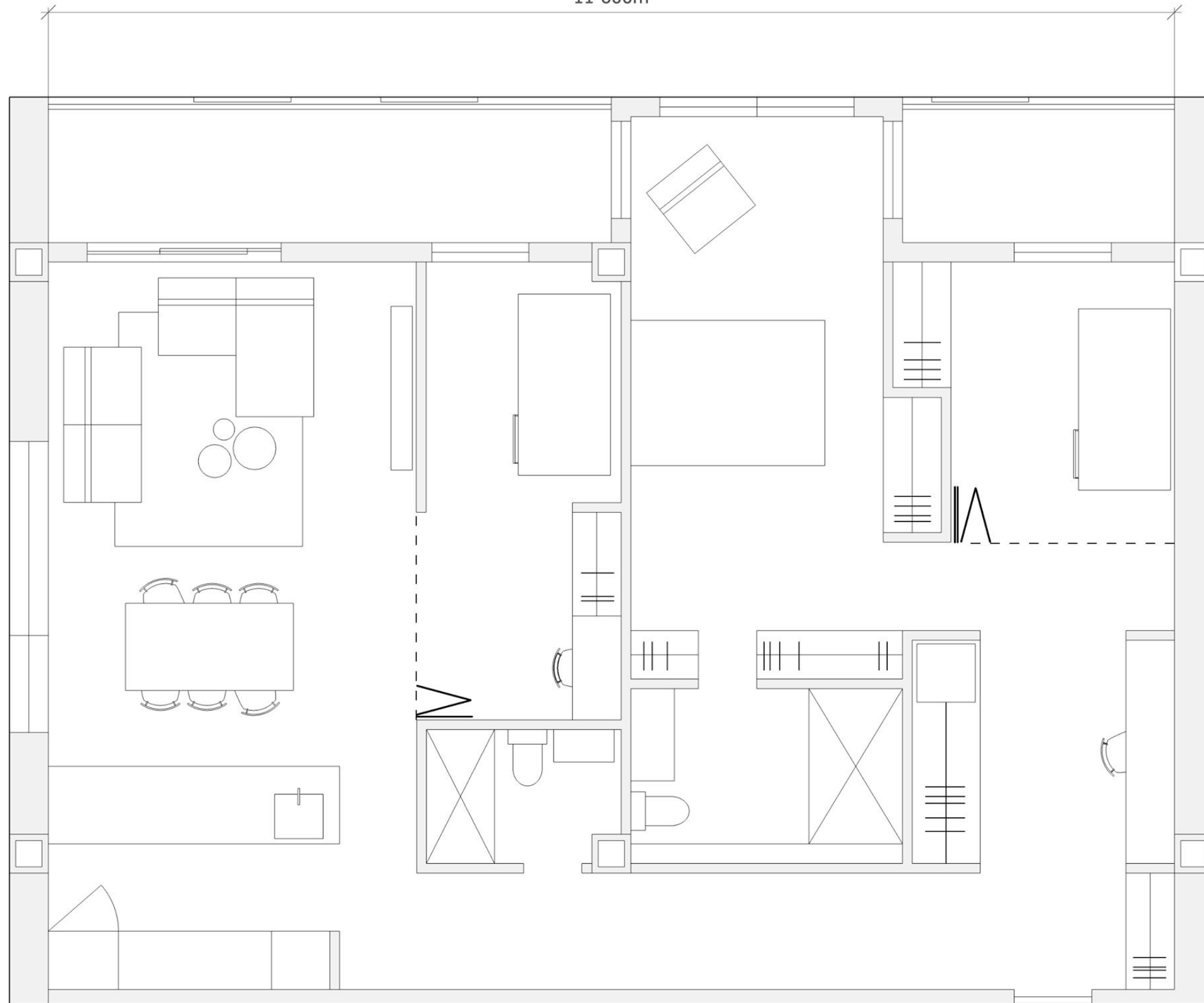

**2 CHAMBRES**

11 600m

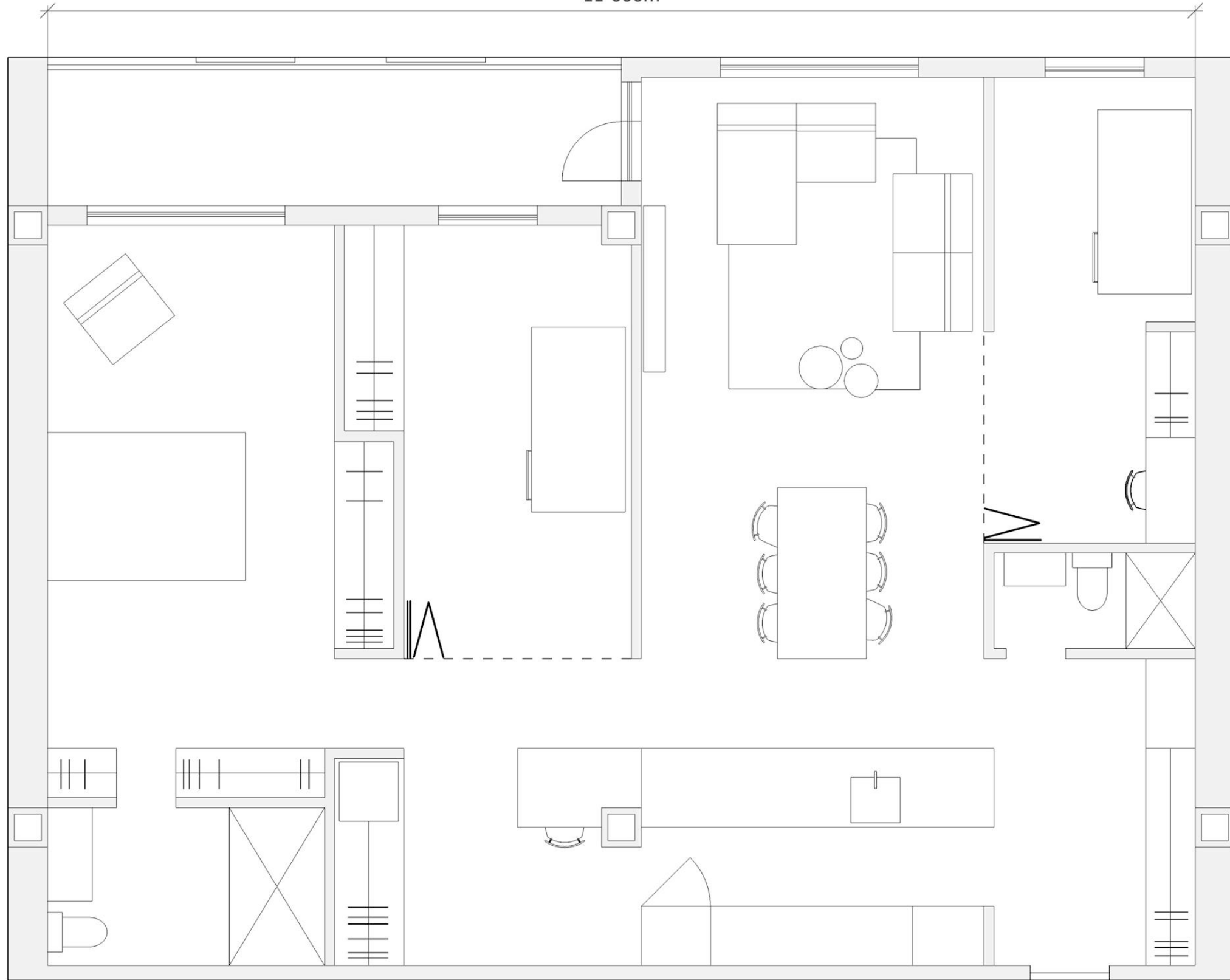

**2 CHAMBRES + UN BUREAU**



# APPARTEMENT 2 CHAMBRES

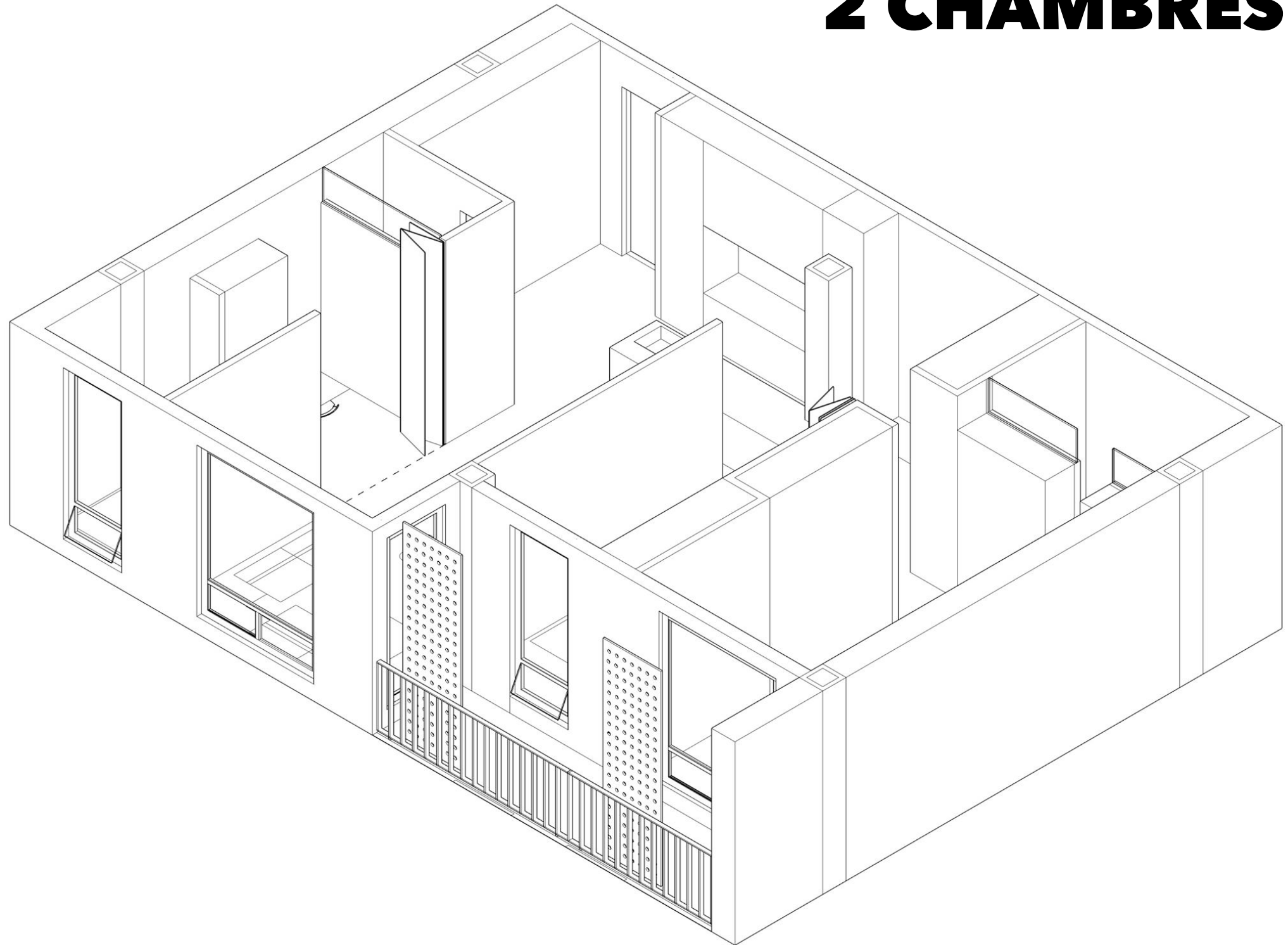

# **AMBIANCE ET VIE DE QUARTIER**

RENDU ET 3D



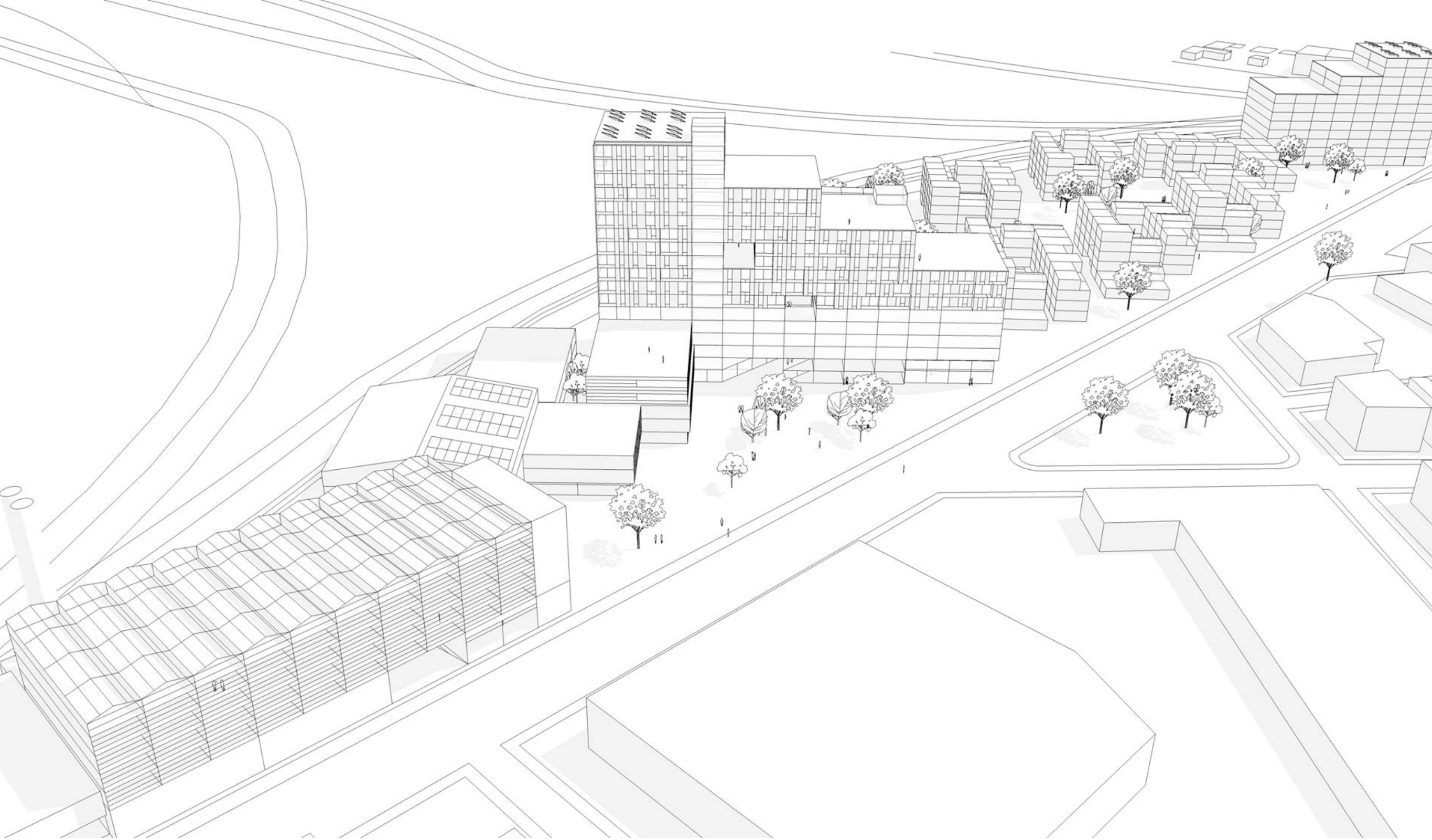



# **PLACE MINÉRALE FACE AUX COMMERCES**







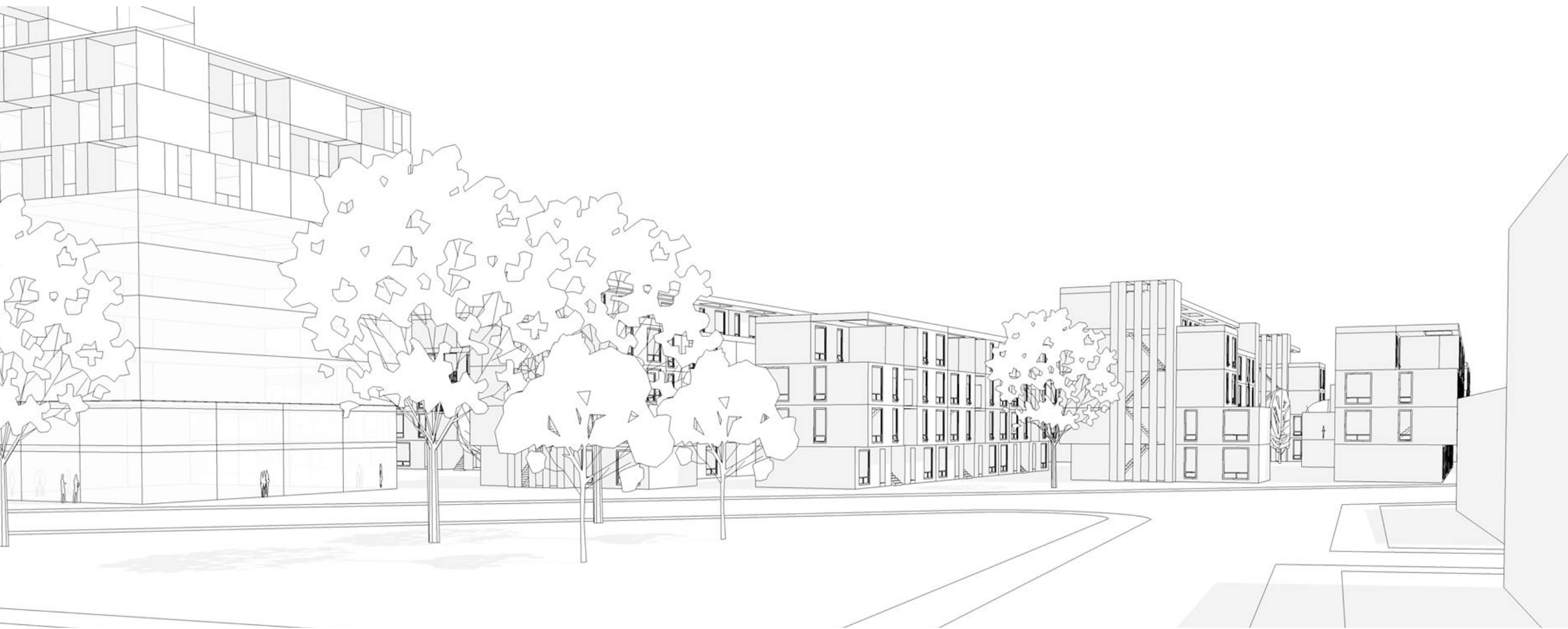





# **FAILLE ET VIE DANS LE PETIT QUARTIER**